

RPS Balcony Hinges

Build Safe, Reliable and Enduring Structures
with RSTEEL® RPS Balcony Hinges



Certified Quality Environment and Safety Management Systems



RPS Balcony Hinges

A UNIQUELY designed solution to connect supported balcony slabs to the building safely while enabling vertical movements of up to 14 mm due to temperature changes. These are steel parts used in pre-cast concrete buildings to transfer horizontal loads from balcony slab to the building floor and at the same time allowing vertical movement of balcony due to temperature changes. RPS balcony hinge consists of R30 or R36 lifting anchor installed to the balcony slab before casting and balcony hinge steel part installed to the floor grouting. These parts are connected with an attachment screw.

The way of connection is different from those of other balcony hinges, there is a connecting plate open on its lower edge, whereby the installation from top down is easy and can be performed without tools.

Features

- It is a unique product as lifting anchor can be reused, so no separate anchors are used for this product.
- Also no cutting is required at the construction site.
- RPS consists of various functional parts which save labour and material during the manufacture, liftings and fastening of the balcony slab.
- It is dimensioned such that its construction also considers the increased U-value requirements of exterior walls.

Attaching the balcony slab

In the first phase the attachment screw is screwed to the R lifting anchor through the rising socket and tightened securely. Attachment screw is locked by damaging the thread before assembly (done at the factory).

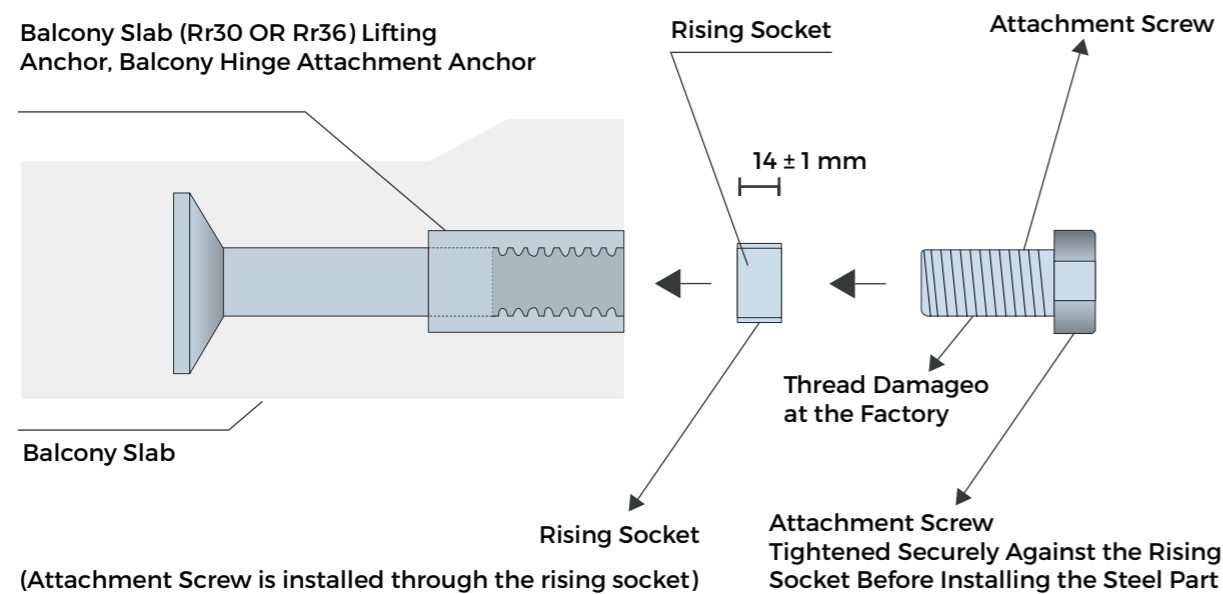

Save Labor and Material cost during manufacturing, lifting and fastening of balcony slabs

In the second phase the U-shaped attachment plate is placed over the rising socket, behind the attachment screw.

Installing the Steel Part

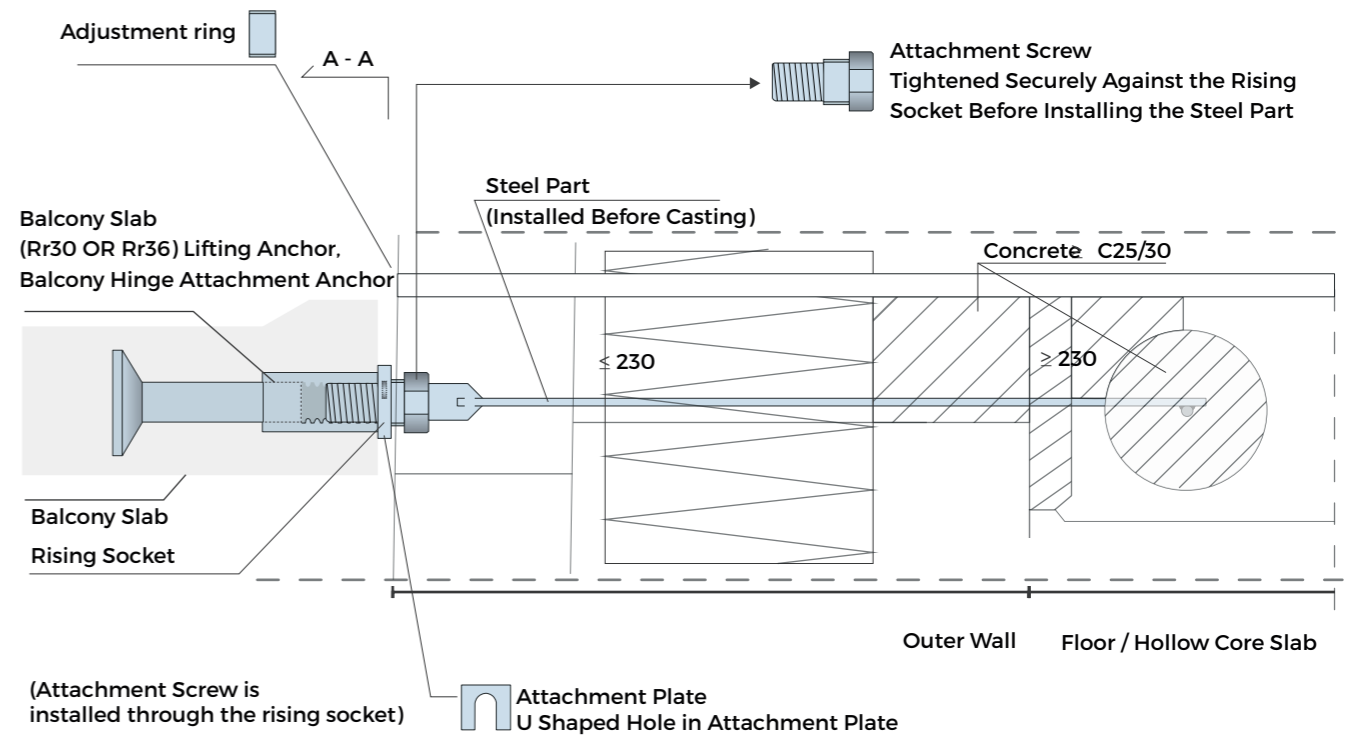
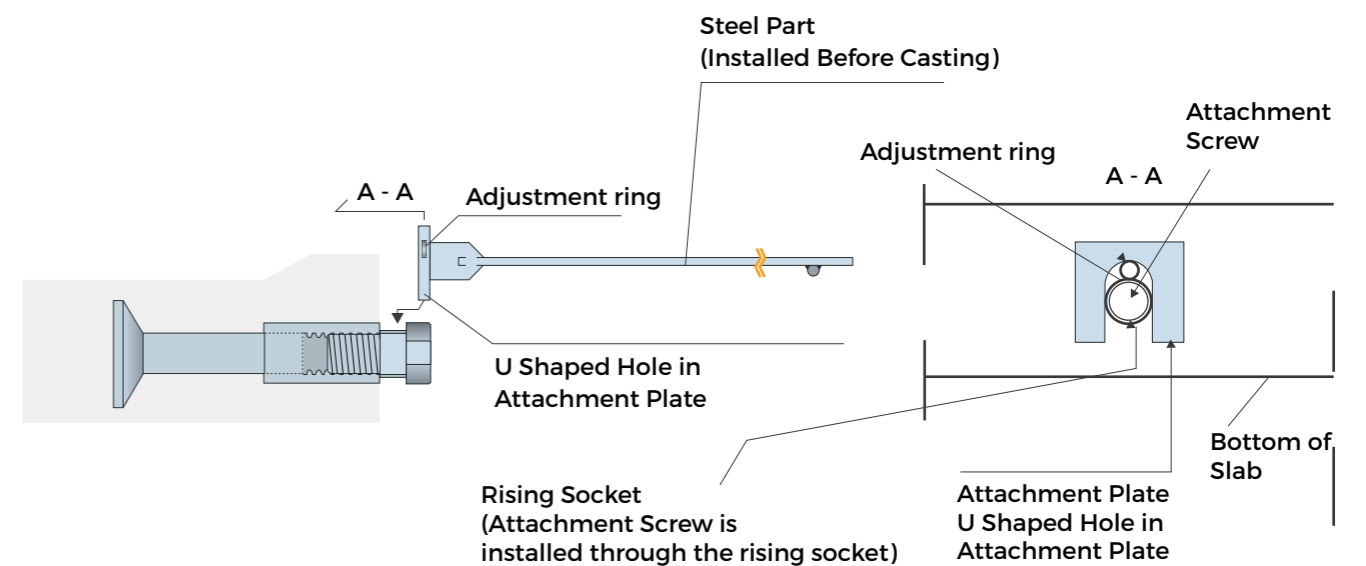

R-Group

We have more than 50 years of experience in the precast concrete industry.

R-Group is a Finnish leading global supplier of precast accessories and concrete connections. With more than 50 years of experience in the precast industry, RSTEEL® provides sustainable solutions for safe, reliable and long-lasting structures throughout the world. RSTEEL® comply with strict quality control in accordance with the guidelines of the Finnish and European Concrete Associations and the ISO 9001- ISO14001 certificates. We are dedicated to providing you with the best quality solutions at competitive prices.

Sales Team

FINLAND

Johannes Kivikangas
+358 40 551 3979
johannes.kivikangas@repo.eu

Tommi Kauramaa
+358 45 204 5535
tommi.kauramaa@repo.eu

CENTRAL AND EASTERN EUROPE

Marvet Suurkivi
+372 526 5480
marvet@repo.eu

WESTERN EUROPE AND NORWAY

Luis Cardoso
+351 927 173 531
luis.cardoso@repo.eu

SWEDEN AND DENMARK

Ivans Kuzins
+371 25 41 0762
ivans.kuzins@repo.eu

ASIA

Mimi Khalid
+60 17 948 2439
mimi.khalid@repo.eu

Technical support : Fatih Aydogmus, technical@repo.eu , +372 5190 7929

OUR WEB & SOCIAL NETWORK

 www.rsteel.fi  info@repo.eu  [/company/13220821/](https://www.linkedin.com/company/13220821/)

HEAD OFFICE
R-GROUP BALTIC OÜ
Kõrtsi tee 7/1, Lehmja küla,
Rae Vald, 75306 Harjumaa, ESTONIA
Mob. +372 578 396 76
Email: info@repo.eu

