



Technical Manual

Technical changes and
errors reserved

Version 4.5.2018

RVS Flat End Fixing Sockets



2017
R-Group Finland OY

 asiakastieto.fi

Table of Content

1. DESCRIPTION OF THE SYSTEM	3
1.1 Manufacturing markings	3
1.2 Quality control	3
2. DIMENSIONS AND MATERIALS	4
2.1 RVS Fixing Socket Dimensions	4
2.2 Materials and ordering code	5
3. RESISTANCES	6
3.1 Design concept	6
3.2 Design resistances	7
3.3 Interaction of forces	7
3.4 Minimum edge distances	8
3.5 RVS fixing socket reinforcement	9
3.5.1 Reinforcement of the pre-cast element	9
3.5.2 Reinforcement for axial pull force	9
3.5.3 Reinforcement for shear loads	11
4. RVS fixing socket usage	12
4.1 Principles for use	12
4.2 Limitations of use	12
4.3 Installation	12

1. Description of the system

RVS fixing sockets system manufactured by R-Group Finland Oy are fixing sockets consisting of steel tube with inner thread and separate ribbed steel anchor bars.

1.1 Manufacturing markings

RVS fixing sockets are marked with R-Steel logo, type and size.

Products are delivered [in cardboard boxes] on a truck palette. Product package is equipped with an R-Steel Pallet Label, which contains the following information: product type, product name, quantity, ISO9001 and ISO14001 quality and environment system markings, and FI and BY (Concrete Association of Finland) logo.

1.2 Quality control

Quality control of the fixing sockets is done according to the requirements of EN 1090-2 and the instructions according to quality and environment system of the R-Group Finland Oy (ISO9001 and ISO14001). R-Group Finland Oy has a quality control contract with Inspecta Sertifointi Oy.

2. DIMENSIONS AND MATERIALS

2.1 RVS Fixing Socket Dimensions

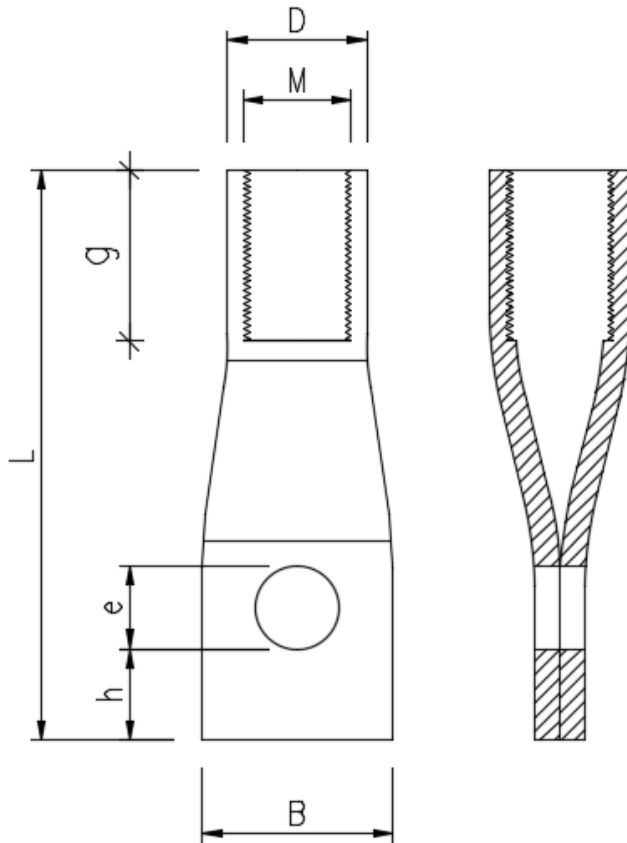

Figure 1. RVS fixing sockets dimensions

Table 1. RVS fixing sockets dimensions

RVS fixing socket	M [mm]	D [mm] 1)	g [mm] ±1	L [mm] +4/-0	B [mm] ±1	h [mm] ±1	e [mm] +1/-0
RVS 10	M10	14	16	50	20	10	10
RVS 12	M12	16	22	60	23	10	10
RVS 14	M14	20	25	80	28	12	14
RVS 16	M16	22	27	90	30	15	14
RVS 20	M20	28	35	95	39	23	16
RVS 24	M24	32	43	105	45	26	18
RVS 27	M27	35	48	125	48	26	20
RVS 30	M30	40	56	140	56	30	20

1) according to EN 10305

2.2 Materials and ordering code

Fixing insert type	Material	Standard
RVS	E355	EN 10305
RVSr	1.4301	EN 10088
RVSh	1.4401	EN 10088

RVS fixing sockets are black steel (uncoated).

RVSr fixing sockets are made of stainless steel and RVSh fixing sockets are made of acid resistant steel.

Ordering codes:

RVS M12 Standard fixing socket (uncoated)

RVSr M12 Stainless steel fixing socket

RVSh M12 Acid resistant steel fixing socket

3. RESISTANCES

3.1 Design concept

Resistances of RVS fixing socket are calculated according to limit state design method given in following standards and instructions:

EN 1992: Eurocode 2

EN 1993: Eurocode 3

Resistances are based on concrete dimensions, anchor steel bars and RVS fixing socket edge distances given in the following sections. Minimum concrete compressive strength at the moment of load application $f_{ck,min} = 25$ MPa (concrete class C25/30).

Safety concept

$$E_d \leq R_d$$

Where E_d = design value of effect of actions placed on RVS fixing socket
 R_d = design resistance of RVS fixing socket

Actions placed on RVS fixing sockets must consider all loads and load safety factors according to EN 1990.

RVS, RVSr and RVSh all have the same resistances.

3.2 Design resistances

Design resistances are for static loads. Resistances for dynamic and fatigue loads must be verified separately.

Table 2. RVS fixing sockets design resistances

RVS fixing socket	Design resistances [kN]	
	Axial pull force F_{Rd}	Shear force V_{Rd}
RVS 10	6.1	3.5
RVS 12	9.7	5.6
RVS 14	14.4	8.3
RVS 16	19.7	9.3
RVS 20	32.5	14.6
RVS 24	42.2	19.6
RVS 27	53.0	27.3
RVS 30	74.8	33.3

Design resistances of RVS fixing sockets given in table 2 are applicable with minimum edge distances and reinforcements presented in section 3.4 and section 3.5.

3.3 Interaction of forces

Interaction of simultaneous axial and shear forces must be considered in the design of RVS fixing sockets. Resistance for simultaneous forces acting on RVS fixing socket may be verified by equation

$$\frac{F_{Ed}}{F_{Rd}} + \frac{V_{Ed}}{V_{Rd}} \leq 1.0$$

Where E_d = design value of effect of actions placed on RVS fixing socket
 F_d = design resistance of RVS fixing socket

3.4 Minimum edge distances

Minimum edge distance for axial pull force is $3 \times d_s$ from the anchor reinforcement (d_s = diameter of anchor reinforcement).

Minimum edge distance and concrete thickness for shear force is given in table 3. If the edge distance for shear force is less than e_v in any direction or the concrete thickness is less than h_c , RVS fixing socket must always be reinforced for shear force, see section 3.5.3.

Table 3. RVS fixing sockets edge distances and concrete thickness for shear force

RVS fixing socket	Edge distance e_v [mm]	Concrete thickness h_c [mm]
RVS 10	150	150
RVS 12	150	150
RVS 14	150	150
RVS 16	150	150
RVS 20	200	200
RVS 24	240	240
RVS 27	300	300
RVS 30	340	340

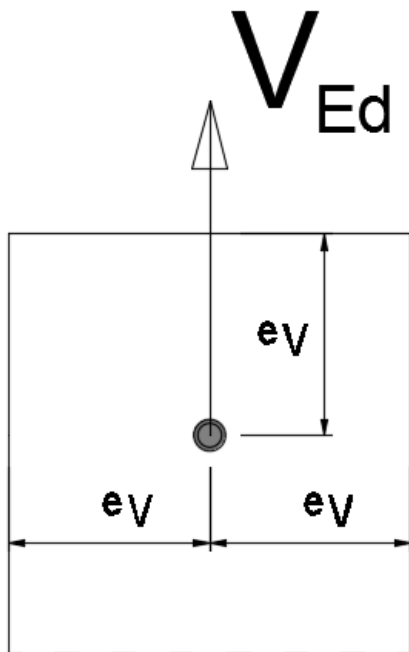

Figure 2. RVS fixing socket edge distances for shear force

3.5 RVS fixing socket reinforcement

Additional reinforcement material for RVS fixing inserts B500B (K500C-T).

3.5.1 Reinforcement of the pre-cast element

The concrete element must have at least minimum reinforcement according to EN 1992-1-1. Concrete element must be reinforced to withstand all actions from applied loads. This reinforcement must be designed by the structural designer.

Area around RVS fixing should always be reinforced to ensure ductile behavior in ultimate limit state.

3.5.2 Reinforcement for axial pull force

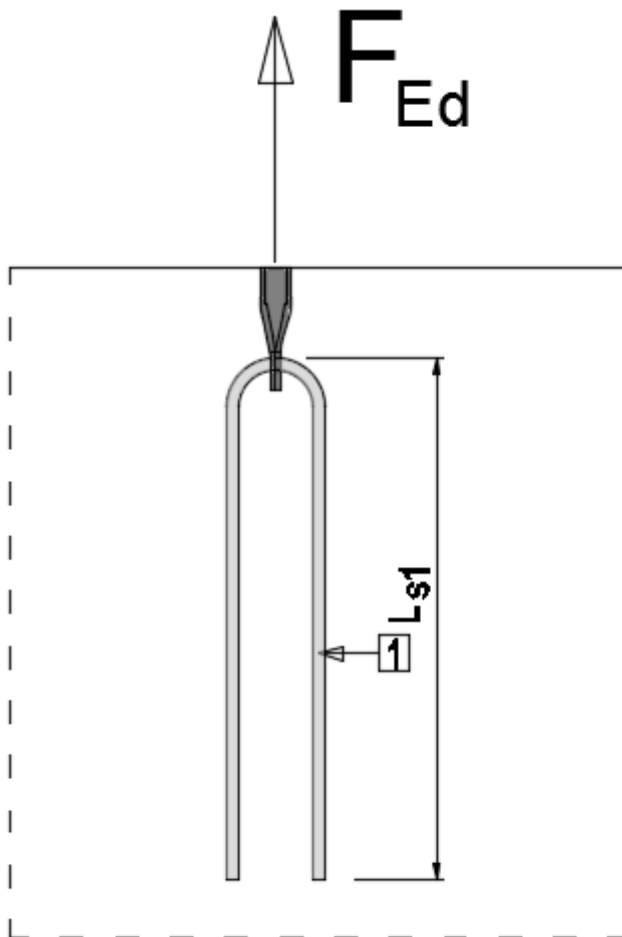

Figure 3. RVS fixing socket reinforcement for axial pull force

RVS fixing sockets must always have anchoring reinforcement **1** for axial pull force according to Figure 3 and Table 4. This reinforcement transfers the load from the RVS fixing socket to the concrete. Anchoring reinforcement must be

installed in to the hole in the RVS fixing socket and it must be in direct contact with lower edge of the reinforcement hole in RVS fixing socket, see Figure 4. Steel material $f_{yk} \geq 500$ MPa.

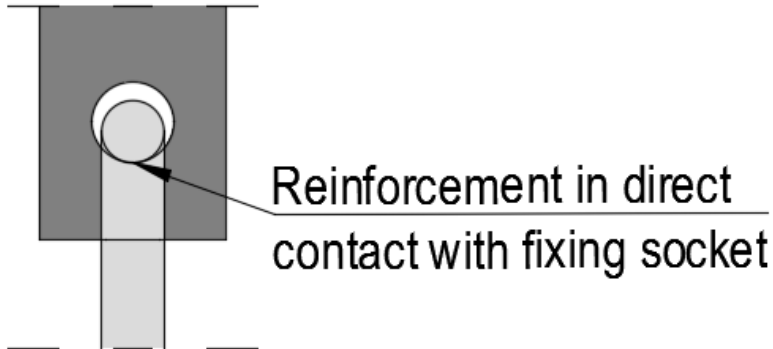

Figure 4. Placing of RVS fixing socket anchoring reinforcement in hole

Table 4. RVS fixing socket anchor reinforcement for axial pull force

RVS fixing socket	Anchor reinforcement ¹	
	Diameter \varnothing_{s1} [mm]	Length L_{s1} [mm]
RVS 10	8	250
RVS 12	8	300
RVS 14	10	300
RVS 16	10	350
RVS 20	12	400
RVS 24	14	450
RVS 27	16	500
RVS 30	16	600

Reinforcement given in this section covers only the anchoring of RVS fixing socket axial pull load.

3.5.3 Reinforcement for shear loads

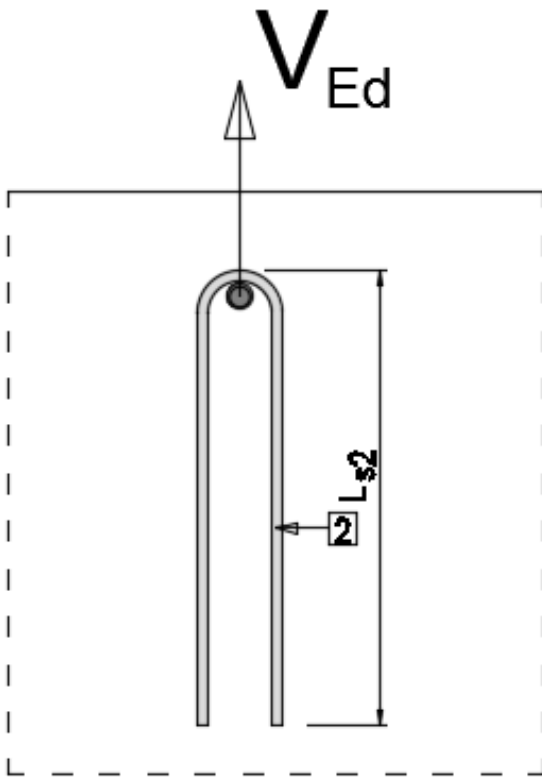

Figure 5. RVS fixing socket reinforcement for shear load

RVS fixing socket reinforcement for shear load must be placed taking into account the direction of the acting shear force.

Table 5. RVS fixing socket reinforcement for shear load

RVS fixing socket	Anchor reinforcement 2	
	Diameter ϕ_{s2} [mm]	Length L_{s2} [mm]
RVS 10	8	250
RVS 12	8	300
RVS 14	10	300
RVS 16	10	350
RVS 20	12	400
RVS 24	14	450
RVS 27	16	500
RVS 30	16	600

4. RVS fixing socket usage

4.1 Principles for use

RVS fixing sockets are used as load transferring steel parts in concrete structures. Fixings must be designed in a way that the failure of one fixing does not lead to detachment of the whole structural element or device.

4.2 Limitations of use

Resistances given for RVS fixing apply for normal density concrete. Structure exposure class must be taken into account when choosing the RVS fixing socket material. In special circumstances, e.g. swimming halls, material suitability must be separately verified.

No welding is allowed to the RVS fixing socket.

Resistance of attached bolt or screw and attached parts for applied loads must be verified separately.

4.3 Installation

During installation, it must be ensured the RVS fixing socket is placed to the correct position according to design. Concrete must be thoroughly vibrated around the RVS fixing socket.

About R-Group

R-Group is a leading provider of steel connections for precast and cast-in- situ construction around the globe.

With over three decades of our participation in huge projects, we don't compromise on quality or customer satisfaction and we create connections for a lifetime.

Our customer-oriented service, excellent and reliable network of suppliers plus our extensive product portfolio ensure that we are able to offer professional and flexible solutions for any kind of projects.



In our operations we comply with the ISO 9001 and 14001 standards

R-Group Finland Oy

Head Office:

Katajanokankatu 6B 12,
00160 Helsinki Finland
Tel : +358 (0)20 722 9420
VAT No. : FI- 2025044-5

RSTEEL[®]

-  www.repo.eu
-  info@repo.eu
-  [linkedin/rsteel](https://www.linkedin.com/company/rsteel)

R-Group Baltic OÜ

Lõõtsa 2B
11415 TALLINN
Mob. : +372 578 396 76



OOO R-Group

18A Bolshoj pr. V.O.
199034, St.Petersburg Russia
Tel : +358 (0)20 722 9420
+372 578 396 76

R-Group Gulf FZE

PO Box 14755
Ras Al Khaymah U.A.E
Tel : +971 505119223
+91 840 894 45 78

© 2018 R-Group Finland OY. All rights reserved.
This manual may not be reproduced in whole
or in part without the prior written approval of
R-Group Finland OY